

**RoHS
Compliant
Drawing For
Reference Only**

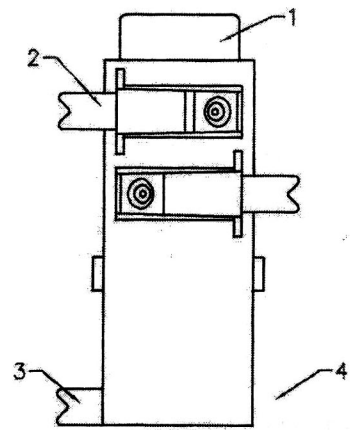
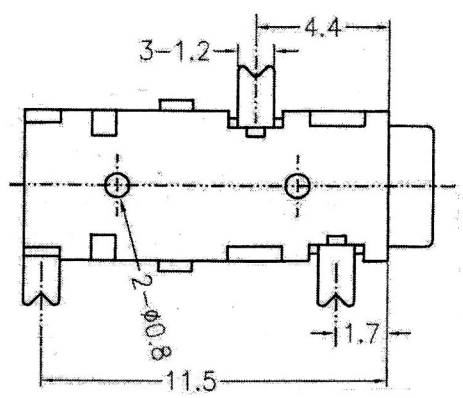
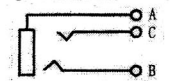
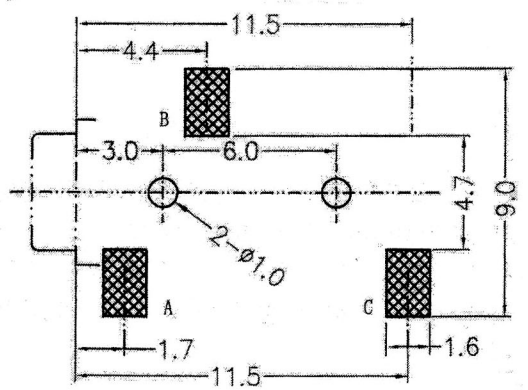
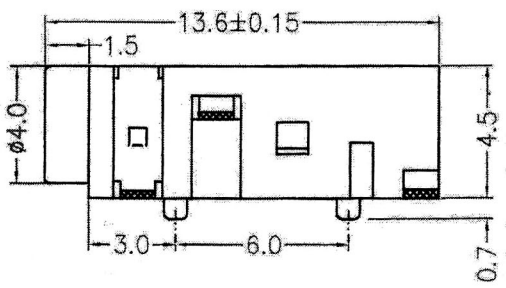
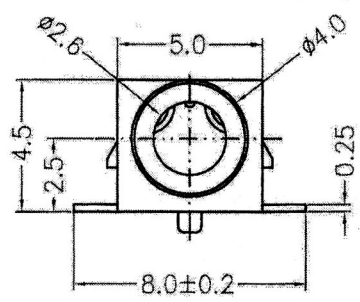

規格書 Specifications

額定負荷 Ratings	DC 30V 0.5 A
絶縁電阻 Insulation Resistance	DC 250V 60 Sec. 100 mΩ Min
抗電強度 Dielectric Voltage	AC 500V (50-60Hz) 60 Sec.
操作力 Operating Force (Kgf)	挿入力 (Insertion Force) 0.3 ~ 2.0 抜出力 (Extraction Force) 0.3 ~ 2.0
負荷壽命 Operating Life With Load	5,000 次 Cycles

- Technical requirement :
1. This product should meet EU RoHS related requirement.
 2. The surface of plastic part should be without any crackle such as burr,lack,and so on phenomenon.
 3. The surface of metal part should be without any defect such as scaur,nick,oxidation and plating problem.
 4. The electronic performance should be the same as spec.
 5. The un-specified tolerance is : ≤ 0.2
 6~20±0.3
 >20±0.4

TOLERANCESE UNIESS OTHERWISE SPEC	
UNDER 1.5 mm	±0.05
1.0 ~ 10.0mm	±0.10
OVER 10.0 mm	± 0.20

NO	PART	MATERIAL	Q'TY	REMARKS
3	Terminal #	PBS Strip	1	Ag Plated Over Ni Plated
2	Contact Terminal	PBS Strip	2	Ag Plated Over Ni Plated
1	Case	PPA	1	Black
NO	PART	MATERIAL	Q'TY	REMARKS

DCI DRAGON CITY INDUSTRIES LIMITED

Item Name	2.5 MM PHONE JACK	Tolerance :
Item No.	ST-5020-02(SL)	Unit : mm

Design	K.W Law	Remark	Scale
Drawing	W.K Yeung	Remark	Material
Check	K.L Wong	Remark	Drawing No. A409031445
Approval	K.W Chan	Remark	Sheet